

# KylCity Freezer

CF-400 CF-500 CF-550

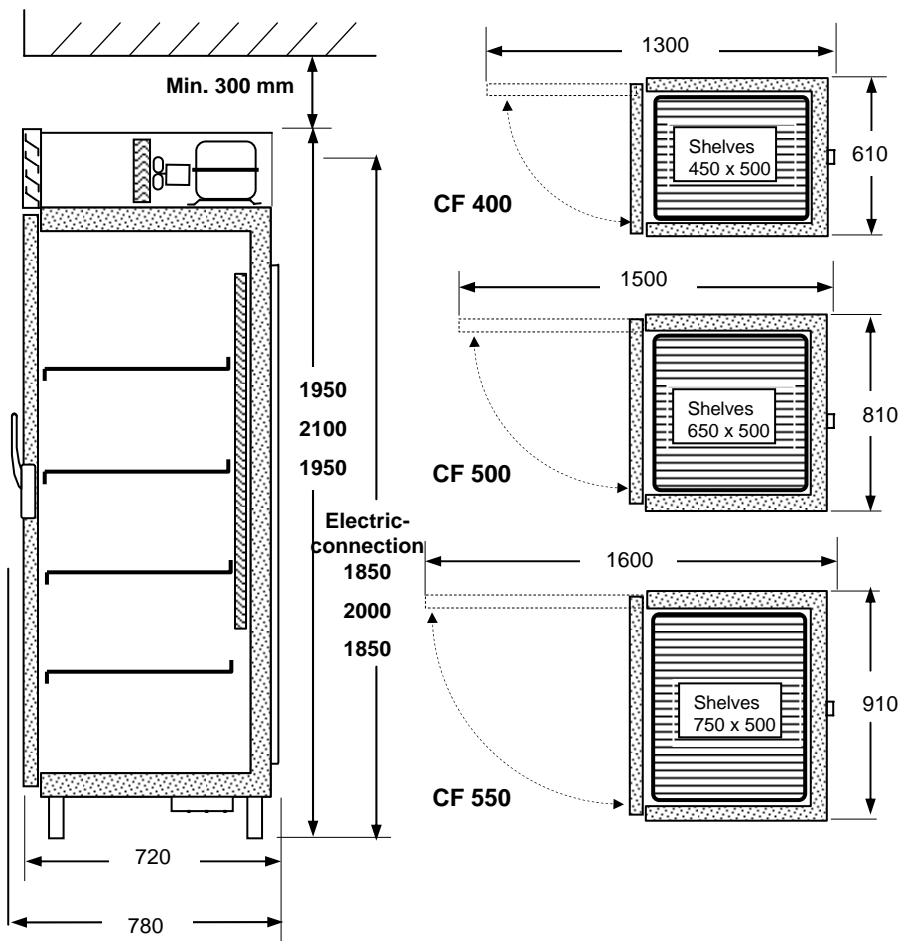

# TECHNICAL INFORMATION



CF-A = incl. compressor

CF-C = excl. compressor

**Design outside**  
St. steel 2333,

**Design inside:**  
St. steel 2333

**Insulation:**  
Freon free polyuretan

**Defrost:** Automatic

**Compressor:** Integrated pipe-system

**Door:** Magnetic seal and lockable handles

**Shelves:**  
Crom

**Ventilation requirements:**  
620-800 m<sup>3</sup>/h

Model:		CF-A	CF-A	CF-A	CF-C	CF-C	CF-C
		400	500	550	400	500	550
Gross volume:	L	410	470	570	410	470	570
Temp. area	C	-30°-10°	-30°-10°	-30°-10°	-30°-10°	-30°-10°	-30°-10°
Outside temp. max	C	+32°	+32°	+32°			
Cooling cap t <sub>2</sub> = - 30° C	W	350	400	450	350	400	450
Power, same for all	V/hz	230-50/60					
Connection effect	W	400	485	560	17	17	24
Energy use*	Kwh/day	6.8	6.8	7.8	0.08	0.08	0.11
Amp.	A	3.8	3.8	4.5	1.12	1.12	1.54
Sound	dB (A)	57 dBa	57 dBa	61 dBa			
Cooling system		R-404 A	R-404 A	R-404 A	R- 404 A	R-404 A	R 404 A
Weight	Kg	120	140	160	105	125	145

With delivery compressor, the cooling pipes and cables are located on top of cabinet. Thermostat, magnetic valve and expansion valve are mounted.

\*Time running 14 hours/24 hours

